

GARAGE DOORS



WIŚNIOWSKI

GATES | WINDOWS | DOORS | FENCES

SECTIONAL DOORS

UniPro SNP 2.0

UniPro SSt 2.0

Intended use: A sectional garage door designed primarily for buildings with a low lintel and narrow side clearance making it impossible to use standard solutions. It is also used for renovation projects, particularly where the garage opening has not been precisely finished.

THERMAL INSULATION

Steel panels are made of galvanized sheet, filled with freon-free, hardened polyurethane foam and coated with polyester paint on both sides. This ensures very good thermal insulation and acoustic properties. Each door features a system of flexible and robust gaskets both along the entire circumference and between the panels, which considerably contributes to the insulating qualities of the door.

SAFETY

Safety systems focus on minimizing all traces of risk. Regardless of the method of operation, WIŚNIOWSKI doors ensure comfort, safety, and security. Our products are fully compliant with the PN-EN 13241 standard.

FUNCTIONALITY

The specially engineered structure of the UniPro SNP 2.0 and UniPro SSt 2.0 garage doors enables quick and convenient installation in garages with non-standard dimensions or limited installation space. This solution is particularly effective for garage complexes with similar opening dimensions.



UniPro SNP 2.0, UniPro SSt 2.0 GARAGE DOOR DESIGN

The design of the UniPro SNP 2.0 and UniPro SSt 2.0 sectional garage doors features a specially designed track and opening frame system (opening frame thickness: 2 mm), enabling adjustment of the door position during installation. This is possible because the tracks are fastened to the opening frames with screws, as well as thanks to the use of special opening frame covers in the garage door colour and because special angle bars can be used to move their fixing point outside their outline. Depending on the customer's preference, the colour of the covers can be changed. The opening frames feature a marking (arrow) at a height of 950 mm from the base, enabling precise alignment at the correct installation height. Additionally, the opening frames are equipped with a system of double installation holes, providing added convenience in the event of installation challenges. As with all Wiśniowski sectional doors, adjustable hinges are used.

Large dimension gates are additionally reinforced with special elements that increase the rigidity of the entire structure, such as an additional hinge fitted in the middle of the door or a door leaf reinforcing profile. Door panels are coated with high quality polyester paints or film-coated. This provides optimum protection against the weather conditions and ensures many years of operation. Thanks to the vast range of colours, WIŚNIOWSKI garage doors can be easily matched to the building's façade. WIŚNIOWSKI doors are an investment that stands the test of time.

1 Automation solutions
Proven and reliable automatic operating units: METRO Smart io, MOTO io or SPARK.

2 Tracks and opening frames
Made of galvanized sheet, they provide a stable and durable structure.

3 Panel hardware in the RAL 9002 colour
The colour matches the panel colour on the inside.

4 Bottom gasket
High quality gaskets perfectly adapt to the shape of the floor and prevent water and dirt from penetrating under the door to the inside of the building.



Torsion springs – UniPro SSt 2.0
spring system installed at the end of horizontal tracks, garage door with double horizontal tracks. The guaranteed minimum number of cycles: 25,000.



Tracks fastened to the opening frame with screws
optimally fastened in the production process.

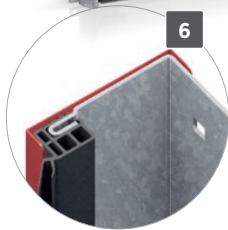

Side gasket + opening frame fascia panel in the garage door leaf colour



Double installation fixing holes
facilitate installation if fitting issues occur.

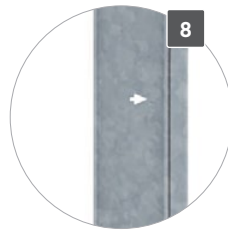

950 mm marking
makes it easier to determine the proper height for fitting the door.



Universal installation method
makes it possible to install the unit with the fascia panel in the clear opening in the case of a narrow side clearance.



Pull springs
a pull spring system mounted along the vertical tracks. Guaranteed minimum number of cycles – 20,000.

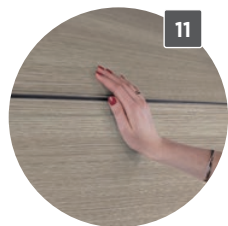

Special panel shape
prevents fingers from being crushed.



Overload safety device
in automatic doors, the door leaf stops and reverses when the bottom edge contacts an obstacle.



Guiding rollers with bearings
ensure proper running of the door leaf.



Photocells
prevent uncontrolled door leaf operation when an obstacle is present within the clear passage – optional accessory.



INSTALLATION DIMENSIONS

- S_o** - opening width
- H_o** - opening height
- N** - minimum required lintel height
- W₁** - minimum required side clearance
- W₂** - minimum required side clearance
- E** - minimum garage depth with clearance under the ceiling
- S_b** - door width, **ordering dimension**
- H_b** - door height, **ordering dimension**
- S_{mN}** - width of the top fascia panel visible in the clear opening, $S_{mN} \leq 50$ [mm]
- S_{mL}, S_{mP}** - width of the side fascia panel visible in the clear opening, $S_{mL}, S_{mP} \leq 50$ [mm]

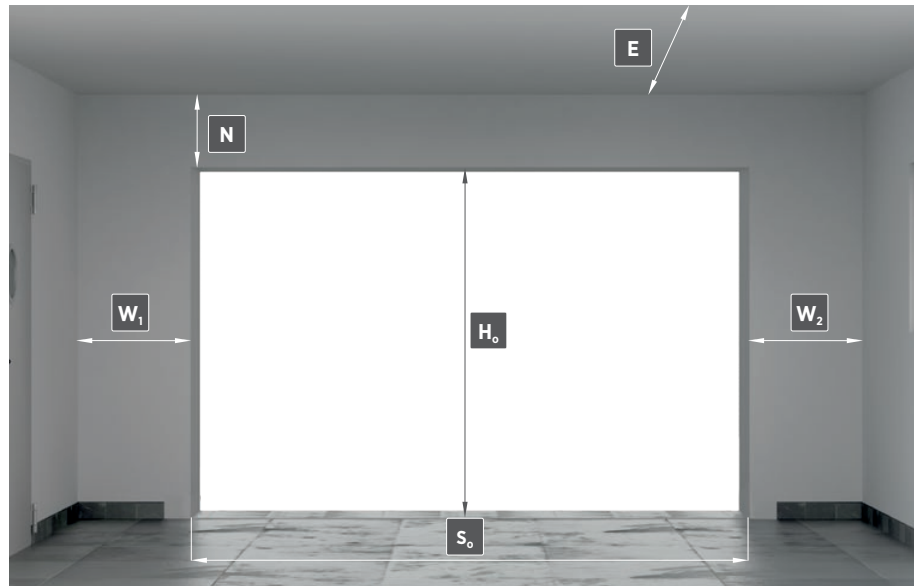

INSTALLATION VERSIONS

Version 1 - when the opening is the same as the ordering dimension

SNP 2.0

SSt 2.0

(1) - MOTO, METRO. (2) - SPARK.

Version 2 - when the opening is up to 100 [mm] wider and up to 50 [mm] higher than the ordering dimension

SNP 2.0

SSt 2.0

(1) - MOTO, METRO. (2) - SPARK.

Set with installation accessories

Includes components enabling installation in two variants: using special angle bars screwed to the outer side of the opening frame and the jamb (outer) wall, as well as using screws installed in the installation holes.

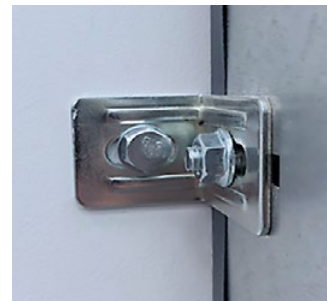

Example: if a customer orders a 3,000 x 2,500 [mm] garage door, it can be installed in an opening with a width of 3,000 – 3,100 [mm] and a height of 2,500 – 2,550 [mm]. When a garage door with dimensions smaller than the garage door opening is installed, a cover is placed inside the clear opening, and side clearance W1 and W2 necessary in order to fit the door is decreased with special angle bars to min. 75 [mm], whereas the lintel Nmin – to 50 mm (for automatic garage doors with the MOTO or METRO drive unit), 70 [mm] (for automatic garage doors with the SPARK drive unit), or 40 mm (for manually operated garage doors). Special angle bars are only used for fixing opening frames. The top fascia panel is not fixed with angle bars.



TRACK SPECIFICATION



SNP 2.0 tracks

Pull springs mounted along the vertical tracks.

Minimum garage door dimensions:

- $S_b = 1,500$ [mm] and $H_b = 1,800$ [mm] - garage doors type **N**
- $S_b = 1,500$ [mm] and $H_b = 1,900$ [mm] - garage doors type **G**, **W**, **V**
- $S_b = 2,230$ [mm] and $H_b = 1,990$ [mm] - garage doors type **K**
- $S_b = \leq 1,750$ [mm] and $H_{b \max.} = 2,500$ [mm], $1,750$ [mm] < $S_b \leq 2,000$ [mm] $H_{b \max.} = 2,750$ [mm]

Available range of dimensions for tracks

| Door height ⁽¹⁾ (H_b) in [mm] up to | Door width ⁽¹⁾ (S_b) in [mm] up to | | | | | | | | | | | | | | |
|---|---|-------|-------|-------|-------|-------|-------|-------|-------|-------|-------|-------|-------|-------|-------|
| | 2,250 | 2,375 | 2,400 | 2,500 | 2,600 | 2,750 | 3,000 | 3,250 | 3,500 | 3,750 | 4,000 | 4,250 | 4,500 | 4,750 | 5,000 |
| 2,000 | | | | | | | | | | | | | | | |
| 2,100 | | | | | | | | | | | | | | | |
| 2,125 | | | | | | | | | | | | | | | |
| 2,200 | | | | | | | | | | | | | | | |
| 2,250 | | | | | | | | | | | | | | | |
| 2,375 | | | | | | | | | | | | | | | |
| 2,500 | | | | | | | | | | | | | | | |
| 2,625 | | | | | | | | | | | | | | | |
| 2,750 | | | | | | | | | | | | | | | |
| 2,875 | | | | | | | | | | | | | | | |
| 3,000 | | | | | | | | | | | | | | | |

- does not apply to doors with the Sandgrain and Smoothgrain film coating.

Installation dimensions

| <input type="checkbox"/> S <input type="checkbox"/> NP <input type="checkbox"/> 2.0 | The opening matches the ordering dimension - version 1 | | The opening is larger than the ordering dimension - version 2 | |
|--|--|--|---|--|
| | SNPN, SNPG, SNPW, SNPK | SNPV | SNPN, SNPG, SNPW, SNPK | SNPV |
| Colour/Structure | all available colour and structure combinations | RAL 9006, RAL 7016, other RAL (silklime) | all available colour and structure combinations | RAL 9006, RAL 7016, other RAL (silklime) |
| Dimension | standard | special | standard | special |
| S_b | | $S_o = S_b$ | | $S_o - S_{mL} - S_{mP}$ |
| H_b | | $H_o = H_b$ | | $H_o - S_{mN}$ |
| N_{min} | Manual | 90 [mm] | | 90 [mm] - S_{mN} |
| | With the MOTO drive | 100 [mm] | | 100 [mm] - S_{mN} |
| | With the METRO drive | 100 [mm] | | 100 [mm] - S_{mN} |
| | With the SPARK drive | 120 [mm] | | 120 [mm] - S_{mN} |
| S_j | | $S_o - 40$ [mm] | | $S_o - 40$ [mm] - $S_{mL} - S_{mP}$ |
| H_j | Manual + catcher (standard) | $H_o - 60$ [mm] | | $H_b - 60$ [mm] - S_{mN} |
| | With a drive unit | $H_o - 60$ [mm] | | $H_b - 60$ [mm] - S_{mN} |
| W_1, W_2 (min.) | | 110 [mm] | | 125 [mm] - S_{mL} , 125 [mm] - S_{mP} |
| E_{min} | Manual | $H_o + 600$ [mm] | | $H_b + 600$ [mm] |
| | With the MOTO drive | $L_s + 300$ [mm] | | $L_s + 300$ [mm] |
| | With the METRO drive | $L_s + 410$ [mm] | | $L_s + 410$ [mm] |
| | With the SPARK drive | $L_s + 363$ [mm] | | $L_s + 363$ [mm] |
| L_s | With the MOTO drive | 2,900 [mm] for $H_o \leq 2,250$; 3,500 [mm] for $H_o > 2,250$ and $H_o \leq 2,850$; 4,500 [mm] for $H_o > 2,850$ | | 2,900 [mm] for $H_b \leq 2,250$; 3,500 [mm] for $H_b > 2,250$ and $H_b \leq 2,850$; 4,500 [mm] for $H_b > 2,850$ |
| | With the SPARK drive | 3288 [mm] for $H_o \leq 2250$; 3831 [mm] for $H_o > 2250$ and $H_o \leq 2750$; 4384 [mm] for $H_o > 2751$ [mm] | | 3288 [mm] for $H_b \leq 2250$; 3831 [mm] for $H_b > 2250$ and $H_b \leq 2750$; 4384 [mm] for $H_b > 2751$ [mm] |

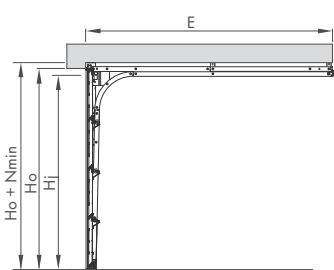

S_o - opening width. **S_b - door width, ordering dimension.** S_j - clear passage width after garage door installation. S_{mN} - width of the top fascia panel visible in the clear opening, $S_{mL}, S_{mP} \leq 50$ [mm]. S_{mL}, S_{mP} - width of the side fascia panel visible in the clear opening, $S_{mL}, S_{mP} \leq 50$ [mm]. H_o - opening height. **H_b - door height, ordering dimension,** H_j - clear passage height after garage door installation. N - minimum required lintel height. W_1 - minimum required side clearance. W_2 - minimum required side clearance. E - minimum garage depth with clearance under the ceiling. L_s - drive rail length. ⁽¹⁾ - Ordering dimension.



TRACK SPECIFICATION



SSt 2.0 tracks

Torsion springs installed at the end of horizontal tracks, garage door with double horizontal tracks – version 2.0

Minimum garage door dimensions:

- $S_b = 1,500$ [mm] and $H_b = 1,800$ [mm] – garage doors **N**
- $S_b = 1,500$ [mm] and $H_b = 1,900$ [mm] – garage doors **G**, **W**, **V**
- $S_b = 2,230$ [mm] and $H_b = 1,990$ [mm] – garage doors **K**
- $S_b \leq 1,750$ [mm] and $H_{b \max} = 2,500$ [mm], $1,750$ [mm] $< S_b \leq 2,000$ [mm] $H_{b \max} = 2,750$ [mm]

Available range of dimensions for tracks

| Garage door height ⁽¹⁾ (H_b) in [mm] up to | Garage door width ⁽¹⁾ (S_b) in [mm] up to | | | | | | | | | | | | | | | |
|--|--|-------|-------|-------|-------|-------|-------|-------|-------|-------|-------|-------|-------|-------|-------|-------|
| | 2,250 | 2,375 | 2,400 | 2,500 | 2,600 | 2,750 | 3,000 | 3,250 | 3,500 | 3,750 | 4,000 | 4,250 | 4,500 | 4,750 | 5,000 | 5,500 |
| 2,000 | | | | | | | | | | | | | | | | |
| 2,100 | | | | | | | | | | | | | | | | |
| 2,125 | | | | | | | | | | | | | | | | |
| 2,200 | | | | | | | | | | | | | | | | |
| 2,250 | | | | | | | | | | | | | | | | |
| 2,375 | | | | | | | | | | | | | | | | |
| 2,500 | | | | | | | | | | | | | | | | |
| 2,625 | | | | | | | | | | | | | | | | |
| 2,750 | | | | | | | | | | | | | | | | |
| 2,875 | | | | | | | | | | | | | | | | |
| 3,000 | | | | | | | | | | | | | | | | |

Installation dimensions

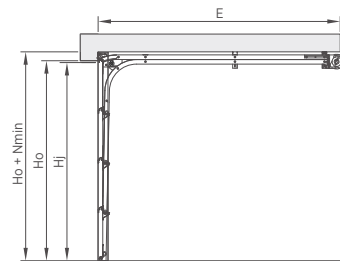

| <input type="checkbox"/> S <input type="checkbox"/> St <input type="checkbox"/> 2.0 | The opening matches the ordering dimension – version 1 | | The opening is larger than the ordering dimension – version 2 | |
|--|--|--|--|--|
| | SStN, SStG, SStW, SStK | SStV | SStN, SStG, SStW, SStK | SStV |
| Colour/Structure | all available colour and structure combinations | RAL 9006, RAL 7016, other RAL (silklime) | all available colour and structure combinations | RAL 9006, RAL 7016, other RAL (silklime) |
| Dimensions | standard, special | | standard, special | |
| S_b | $So = S_b$ | | $So - SmL - SmP$ | |
| H_b | $Ho = H_b$ | | $Ho - SmN$ | |
| Nmin | Manual | 100 [mm] | 100 [mm] – SmN | |
| | With the MOTO drive | 140 [mm] | 140 [mm] – SmN | |
| | With the METRO drive | 140 [mm] | 140 [mm] – SmN | |
| | With the SPARK drive | 150 [mm] | 150 [mm] – SmN | |
| | Sj | $So - 40$ [mm] | $So - 40$ [mm] – SmL - SmP | |
| Hj | Manual | $Ho - 160$ [mm] | $Ho - 160$ [mm] – SmN | |
| | Manual + catcher (standard) | $Ho - 90$ [mm] | $Ho - 90$ [mm] – SmN | |
| | With a drive unit | $Ho - 90$ [mm] | $Hb - 90$ [mm] – SmN | |
| | W1, W2 (min.) | 110 [mm] | 125 [mm] – SmL, 125 [mm] – SmP | |
| Emin | Manual | $Ho + 750$ [mm] | $Hb + 750$ [mm] | |
| | With the MOTO drive | $Ls + 300$ [mm] | $Ls + 300$ [mm] | |
| | With the METRO drive | $Ls + 410$ [mm] | $Ls + 410$ [mm] | |
| | With the SPARK drive | $Ls + 363$ [mm] | $Ls + 363$ [mm] | |
| Ls | With the MOTO drive | 2,900 [mm] for $Ho \leq 2,250$; 3,500 [mm] for $Ho > 2,250$ and $Ho \leq 2,850$; 4,500 [mm] for $Ho > 2,850$ | 2,900 [mm] for $Hb \leq 2,250$; 3,500 [mm] for $Hb > 2,250$ and $Hb \leq 2,850$; 4,500 [mm] for $Hb > 2,850$ | |
| | With the METRO drive | | | |
| | With the SPARK drive | 3,288 [mm] for $Ho \leq 2,320$; 3,831 [mm] for $Ho > 2,321$ and $Ho \leq 2,863$; 4,384 [mm] for $Ho > 2,864$ | 3,288 [mm] for $Ho \leq 2,320$; 3,831 [mm] for $Ho > 2,321$ and $Ho \leq 2,863$; 4,384 [mm] for $Ho > 2,864$ | |

So – opening width. **S_b** – door width, ordering dimension. S_j – clear passage width after garage door installation. SmN – width of the top fascia panel visible in the clear opening, $Sm \leq 50$ [mm]. SmL , SmP – width of the side fascia panel visible in the clear opening, SmL , $SmP \leq 50$ [mm]. Ho – opening height. **H_b** – door height, ordering dimension. H_j – clear passage height after garage door installation. N – minimum required lintel height. W_1 – minimum required side clearance. W_2 – minimum required side clearance. E – minimum garage depth with clearance under the ceiling. L_s – drive rail length. ⁽¹⁾ – Ordering dimension.



PANEL STRUCTURE

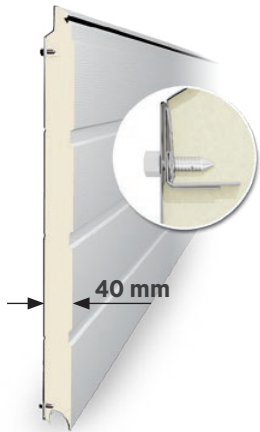

Robust and reliable design

We consistently follow the same design principles for our whole range of sectional garage doors. Thanks to our robust and reliable design, you can rest assured that the door will meet even the most extreme requirements and withstand the most demanding operating conditions. Special solutions, such as our proprietary panel built using the **5-ply** sheet bending system, ensure stable fixation of elements, which further contributes to the strength of the structure. The top section is fitted with a lip gasket. The internal side of the panel in the RAL 9002 colour. The panel is infilled with polyurethane foam whose composition is precisely determined by our specialists.

RIB TYPES



G - without ribs



W - high ribs



N - low ribs



K - caisson ribs



V - V ribs

TEXTURES



Woodgrain



Smoothgrain

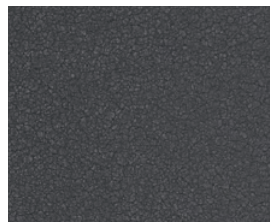

Sandgrain

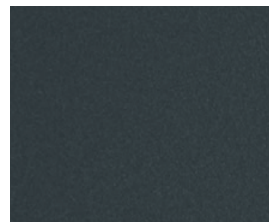











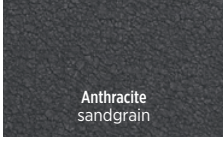



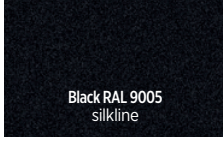
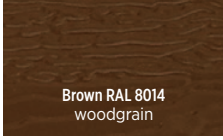





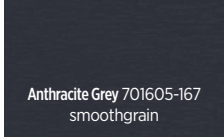
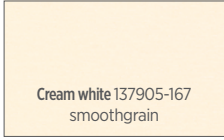
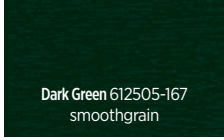

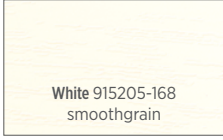
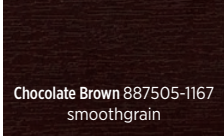
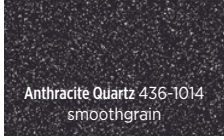
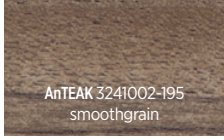
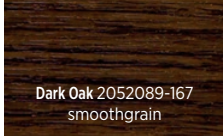
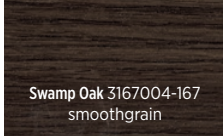
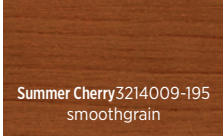
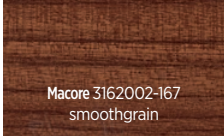

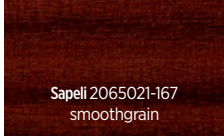
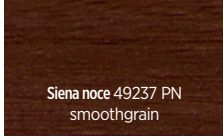
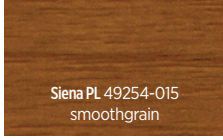
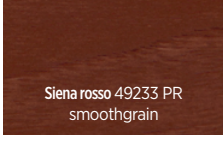

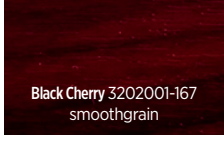
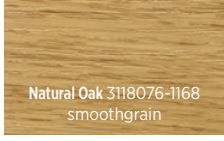
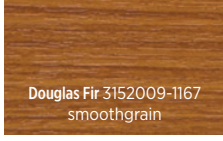
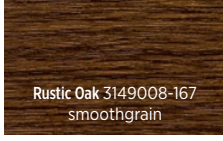

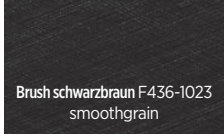
Silkline

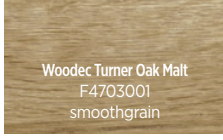

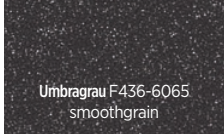
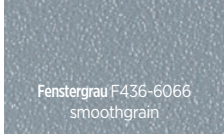
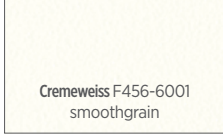
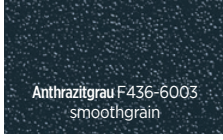
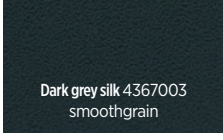
Silkline, panel with V ribs

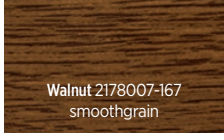
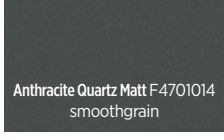

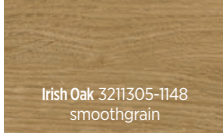
AVAILABLE COLOURS:

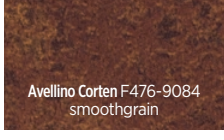
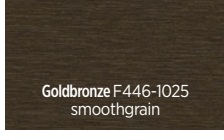
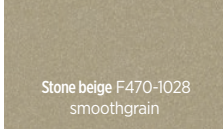
| | | | | | |
|--|---|---|---|--|--|
|  Anthracite sandgrain |  Golden Oak woodgrain |  Walnut woodgrain |  Graphite RAL 7016 woodgrain |  Graphite RAL 7016 silkline |  Black RAL 9005 silkline |
|  Brown RAL 8014 woodgrain |  Silver RAL 9006 woodgrain |  Silver RAL 9006 silkline |  White RAL 9016 woodgrain |  White RAL 9016 silkline |  Golden Oak smoothgrain |
|  Walnut smoothgrain |  Anthracite Grey 701605-167 smoothgrain |  Cream white 137905-167 smoothgrain |  Dark Green 612505-167 smoothgrain |  Metbrush silver F436-1002 smoothgrain |  Silbergrau 116700 smoothgrain |
|  White 915205-168 smoothgrain |  Chocolate Brown 887505-1167 smoothgrain |  Anthracite Quartz 436-1014 smoothgrain |  AnTEAK 3241002-195 smoothgrain |  Dark Oak 2052089-167 smoothgrain |  Swamp Oak 3167004-167 smoothgrain |
|  Summer Cherry 3214009-195 smoothgrain |  Macore 3162002-167 smoothgrain |  Oregon 1192001-167 smoothgrain |  Sapeli 2065021-167 smoothgrain |  Siena noce 49237 PN smoothgrain |  Siena PL 49254-015 smoothgrain |
|  Siena rosso 49233 PR smoothgrain |  Winchester 49240 XA smoothgrain |  Black Cherry 3202001-167 smoothgrain |  Natural Oak 3118076-1168 smoothgrain |  Douglas Fir 3152009-1167 smoothgrain |  Rustic Oak 3149008-167 smoothgrain |
|  Sheffield oak light F 456-3081 smoothgrain |  Sheffield oak grey F 436-3086 smoothgrain |  Brush schwarzbraun F436-1023 smoothgrain |  Earl platin 119500 smoothgrain |  Black ultra-mat PX47097 smoothgrain |  Woodec Turner Oak Malt F4703001 smoothgrain |
|  Woodec Sheffield Oak Alpine F4703002 smoothgrain |  Woodec Sheffield Oak Concrete F4703003 smoothgrain |  Umbragrau F436-6065 smoothgrain |  Fenstergrau F436-6066 smoothgrain |  Cremeweiss F456-6001 smoothgrain |  Anthrazitgrau F436-6003 smoothgrain |
|  Dark grey silk 4367003 smoothgrain |  Golden Oak 2178001-167 smoothgrain |  Walnut 2178007-167 smoothgrain |  Anthracite Quartz Matt F4701014 smoothgrain |  Woodec Turner Oak Toffee F4703004 smoothgrain |  Irish Oak 3211305-1148 smoothgrain |
|  Sable Noir 2100 silkline |  Sable Noir 2100 woodgrain |  Avellino Corten F476-9084 smoothgrain |  Goldbronze F446-1025 smoothgrain |  Stone beige F470-1028 smoothgrain | |



Our paint range includes over 200 colours from the RAL palette.

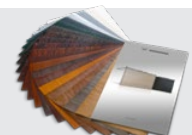

Film coatings available with garage doors with the panel: G - without ribs or W - with high ribs



HOME INCLUSIVE 2.0 colours

The Home Inclusive 2.0 colour collection combines four product groups: Gates | Windows | Doors | Fences, which provide a consistent design of all the products.

HI EARTH

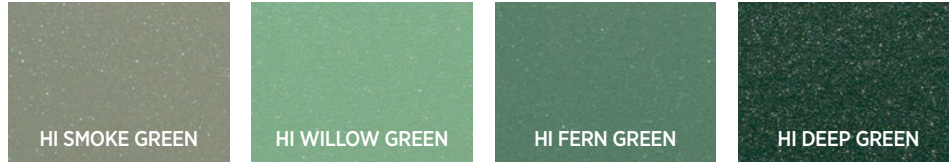

HI STONE



HI STEEL



HI RUBY

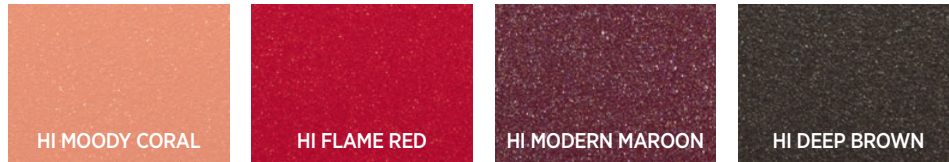

Special colours from the HI palette:

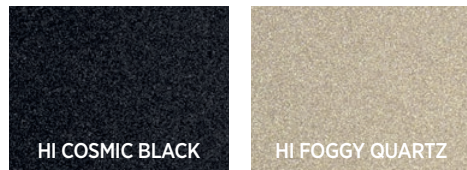

Doors in light colours should be fitted on the side exposed to sunlight. It is not recommended to fit dark colour doors in such conditions, in particular RAL: 3007, 4006, 4007, 5004, 5008, 5010, 5011, 5020, 5022, 6008, 6009, 6015, 6022, 7015, 7016, 7021, 7024, 7026, 7043, 8014, 8019, 8022, 9004, 9005, 9011, 9017, 9021, Anthracite, Walnut, Macore, Dark Oak, Swamp Oak, Siena Noce, Siena Rosso, Quartz Anthracite, Summer Cherry, Sapeli, Dark Green, Sheffield Oak Brown, Rustic Oak, Chocolate Brown, Black Ulti-Mat, Brush Schwarzbrown, Umbragrau, Anthrazitgrau.

When a dark colour is chosen for doors installed on the side exposed to sunlight, the panels can heat up excessively, which may result in deformation. The door leaf cannot be painted from the inside. When ordering doors in matching colours in different orders (delivery batches), the colour hues can differ due to technological reasons.



OPTIONAL ACCESSORIES

PORTHOLES

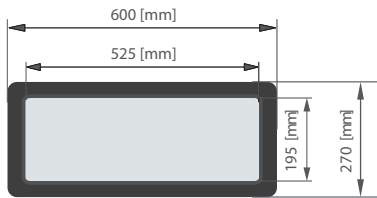

Type A-1 – made of double, clear acrylic glass, with a rough frame surface. The external frame is available in RAL 7016, RAL 8003, RAL 8011, RAL 8014, RAL 8017, RAL 9005, RAL 9016. The internal frame is always white. Internal/external frame made of PVC. External dimensions of the frame: 600 x 270 [mm]. Light transmission 86%.

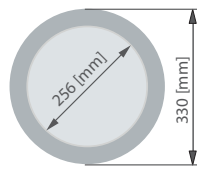

Type O-1A

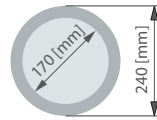

Type O-2A

Type O-1A, O-2A – infill: triple, clear, acrylic glazing unit; frame (ext./int.): stainless steel, satin. Not available with doors with caisson ribs. Available with doors up to $So=3,750$ mm.

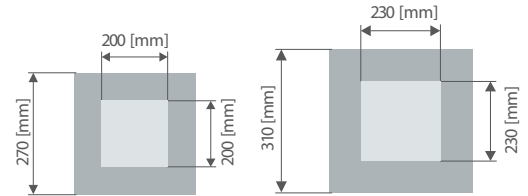

Type R-1A

Type R-2A

Type R-1A, R-2A – infill: triple, clear, acrylic glazing unit; frame: stainless steel, satin. Not available with doors with caisson ribs. Available with doors up to $So=3,750$ mm.

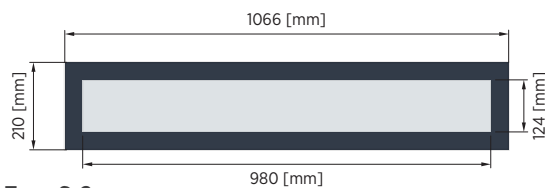

Type S-2

Type S-2 – unit made of double clear acrylic glass, aluminium frame with external dimensions of 1,066x210 [mm]. The external frame is available in RAL 7016, HI Modern Graphite, RAL 9005, Modern Black, RAL 9016, RAL 8003, RAL 8011, RAL 8014. Internal frame always in RAL 9002.

GLASS

Intended use: for double glazing of glazed aluminium panels and VISUAL glazing.



No-Scratch

Glass pane with a special coating improving its strength, very good resistance to scratching and sunlight compared to standard glass.



Satin

Opaque glass pane. Double glazed pane opaque from the outside and clear from the inside. Light transmission 78%.



Glass pane SAN R

Opaque (so-called frosted) double glazed pane clear from the inside. Light transmission (77-79%).



Grey

Clear glass with a slight brown hue. Double glazed pane, clear from the inside, non-coloured from the inside. Light transmission (51%).

VENTILATED PANEL



Aluminium panel without a thermal break or with a thermal break, infilled with expanded mesh. The door can be fitted with only one ventilated panel.



LOCK/HANDLE

The lock is fitted with a single-side lock cylinder, the lock cylinder is accessible from the outside (three keys), from the inside the lock is operated with a latch. In the manually operated SNP door with $S_o \geq 4,000$ [mm], the lock engages the deadbolt on both sides (single-side locking is available as an optional accessory). On the outside of the door leaf, a plastic handle with a cover plate type PVC-1 or KL-2 is fitted. A black plastic handle is installed on the inside. The UniPro SNP and SNP 2.0 doors are not available with a handle fitted in the middle of the door. The PVC-1 handle is available in black. The KL-2 handle is available in the following colours:

- **MAT** – RAL 9005, RAL 9016, RAL 8014.
- **GLOSS** – RAL 9006, RAL 1036, RAL 1035, RAL 7048.



KL-2 handle, colour: RAL 9006



KL-2 handle, colour: RAL 1036



KL-2 handle, colour: RAL 1035



KL-2 handle, colour: RAL 7048



KL-2 handle, colour: RAL 9016



KL-2 handle, colour: RAL 9005



KL-2 handle, colour: RAL 8014



Standard handle

PRE-ASSEMBLY OF EXTENSION SPRINGS



It is possible to order pre-assembled extension springs for the UniPro SNP 2.0 sectional garage door. The option enables quicker and easier door installation.

PAINTED HINGES



An option is available to paint the central and side hinges of the garage door in RAL 9002



EXAMPLE UniPro SNP 2.0, UniPro SSt 2.0 DOOR MODELS

GLAZING



Garage door with portholes - type A-1



Garage door with portholes - type C-1



Garage door with portholes - type E-1



Garage door with portholes - type O



Garage door with portholes - type O-1A,
stainless steel frame



Garage door with portholes - type O-2A,
stainless steel frame



Garage door with portholes - type R-1A,
stainless steel frame



Garage door with portholes - type R-2A,
stainless steel frame



Garage door with portholes - type S-2,
aluminium frame, painted



Garage door with portholes - type W4-1



Garage door with portholes - type W5-1



Garage door with portholes - type W3-1



Garage door with portholes - type W6-1



DECORATIVE MOTIFS



Type Ap-1



Type Ap-2



Type Ap-3



Type Ap-4



Type Ap-5



Type Ap-6

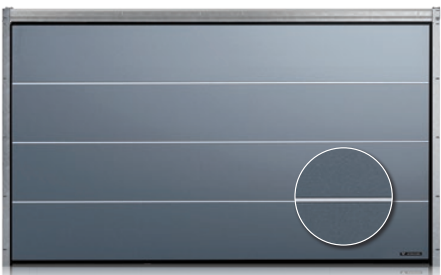

Type Ap-7 in garage doors with panels without ribs



Type Ap-7 in garage doors with panels with high ribs



The Ap-1 – Ap-6 decorative motifs are available in stainless steel colour and RAL 9005. Ap7 decorative motifs are available in stainless steel and copper-clad stainless steel colours.

OTHER MANUFACTURING OPTIONS



Garage door with an aluminium panel glazing



Garage door with a ventilated panel - expanded mesh



Garage door with a pet door



Garage door with the VISUAL glazing - available for garage door widths up to So=3,000 [mm]



Garage door with the HORIZON glazing



OPTIONAL ACCESSORIES

WICKET DOOR

The standard clear passage width is 900 [mm], the clear passage height can range from 1700 [mm] to 2027 [mm] depending on the height of the door and panels used.

- The minimum dimensions of a garage door in which a wicket door can be fitted are 2000 x 2000 [mm] (So x Ho).
- The wicket door is available for garage doors with a glazed or ventilated panel with So ≥ 2400 [mm].
- Drip strip in door hardware colour.
- Threshold -100 [mm] high (including the door gasket -40 [mm] high).
- The bottom door edge is fitted with a brush seal.
- Wicket door for doors with the SSt 2.0 tracks can be manufactured with a minimum lintel of 140 [mm]. In garage doors with the SNP 2.0 tracks, with a minimum lintel of 115 [mm] for doors with the MOTO io and METRO Smart io drive units, 135 [mm] for doors with the SPARK drive unit.
- In garage doors with the SSt 2.0 tracks, a wicket door additionally reduces the “Hj” dimension by about 50 [mm], and in garage doors with the SNP 2.0 tracks – by about 190 [mm] (standard threshold) or 180 [mm] (low threshold).
- As standard, the wicket door is installed in the centre of the door leaf. In garage doors with the SSt 2.0 tracks, the door can be installed close to the right or left edge (as seen from the inside), opening direction: right or left, outswing, outfitted with a handle with a cover plate on both sides and a lock with a cylinder lock (three keys).
- One-key system – the lock in the wicket door and the lock in the garage door are opened with a single key (this does not apply to doors fitted with an anti-burglary lock cylinder).
- The door hardware, as well as the top and bottom hardware of the garage door, is made of aluminium.
- The wicket door option in automatic doors includes a wireless wicket door opening sensor for doors with the MOTO io and METRO Smart io drive units, and a wired wicket door opening sensor for doors with the STARK drive unit.

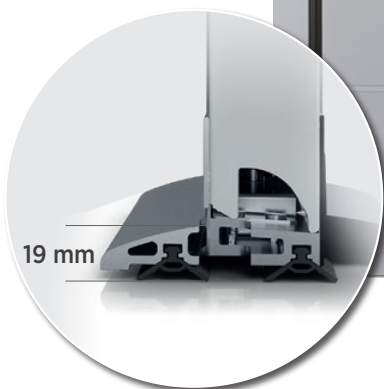
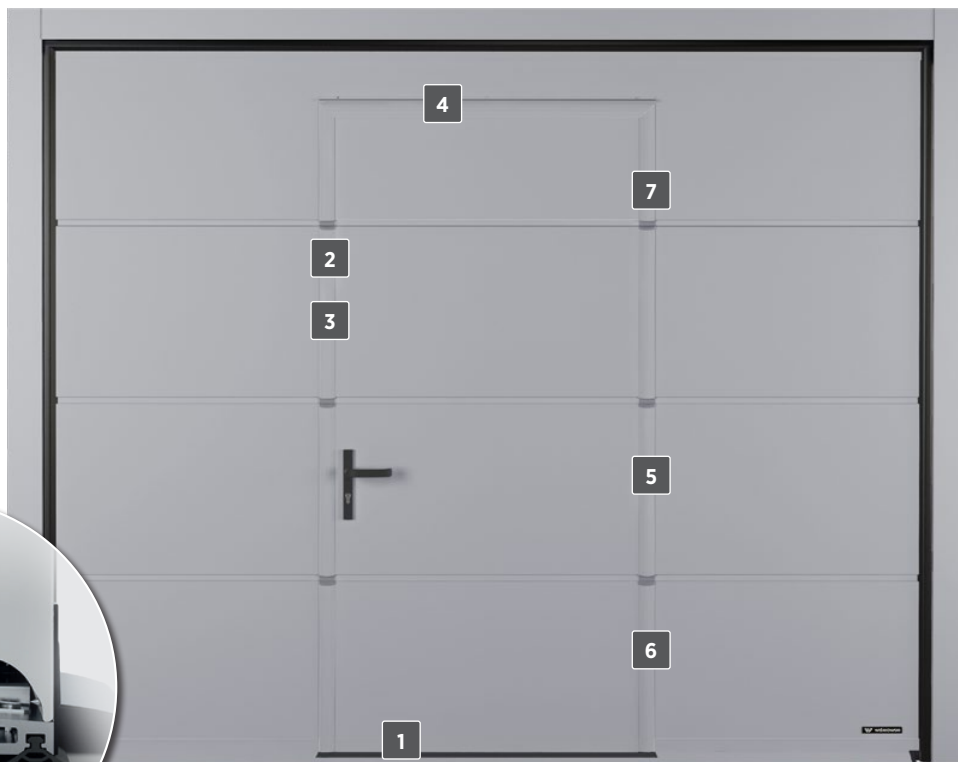

19 mm

Low threshold 19 mm high minimizes the number of obstacles in the passageway (optional accessory).



1 **Wicket door** fitted with a threshold 100 [mm] high (including a 40 [mm] gasket) as standard.



2 **The wicket door opening sensor** prevents activation of the garage door when the wicket door is open. The wicket door option in automatic doors includes a wicket door opening sensor.

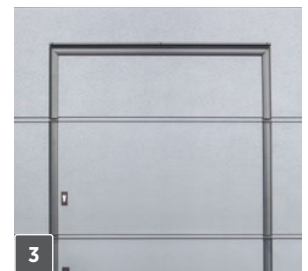

3 **Hardware** made of aluminium, in a colour matching the garage door leaf colour.



4 Drip cap (standard accessory).



6 Concealed hinges that can be adjusted.



Rail door closer (standard accessory).

The rail door closer is supplied as standard with a wicket door installed in manually operated and power operated doors. It is fixed to the top hardware of the wicket door on the inside of the door. It is fitted with a restrictor. The hold open device cannot be installed in a wicket door.



5 System preventing the leaf from dropping.



7 Distance brackets with a safe shape, ensuring better tightness.



Concealed door closer (optional accessory).

Concealed door closer available in a full scope of dimensional ranges of the doors compatible with a wicket door. The wicket door can optionally be fitted with a concealed door closer instead of a rail door closer. A wicket door restrictor cannot be installed. A hold open device can be fitted.

HARDWARE IN A DECOR COLOUR

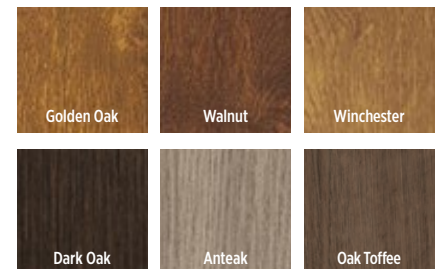
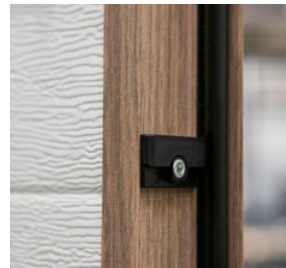
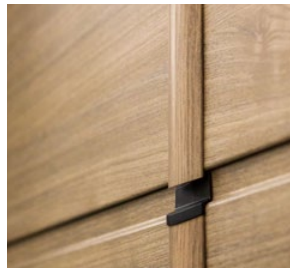

Decor colour of the wicket door hardware

a method of decorating aluminium parts by transferring photosensitive organic pigments from a special film onto a layer of polyester powder coat. As a result, a durable and decorative coating which imitates the natural grain of wood is obtained.

Decor colour of the wicket door hardware – available colours

TRI-LOCK LOCK FOR WICKET DOORS

Key features of the lock:

- **Multi-point locking** – a wicket door equipped with the new lock will have three locking points strategically placed around the perimeter of the door to ensure even distribution of the locking force and a tight and secure closure.
- **Locking points (deadbolts)** – designed to best lock the door leaf at the striker points.
- **Strikers** – mounted on the hardware, they ensure solid latching of the lock elements at the designated points.
- **Three points of the lock** controlled with a handle, the pressing of which unlocks the locking points.
- **Additional locking point in the main lock** controlled with a key, constituting an additional safeguard against unauthorized opening.

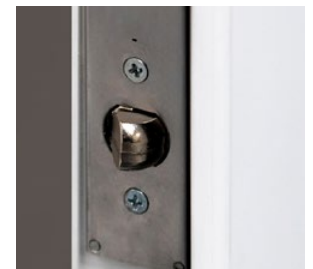
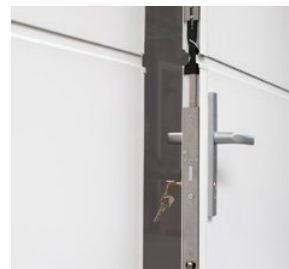
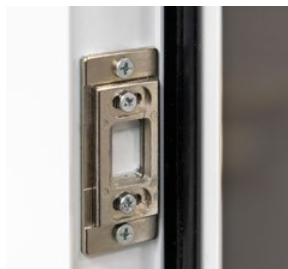



AUTOMATIC OPERATING UNIT KITS

The METRO Smart io, MOTO io, and SPARK series drive units are dedicated for garage doors and ensure full functionality and overload protection as standard.

The EXTENDED CARE warranty allows you to extend the standard warranty for a complete product – an automatic sectional door – up to 5 years, provided it is factory-configured with the METRO Smart io, MOTO io, or SPARK drive unit.



| Drive unit type | | METRO smart io | MOTO io | SPARK |
|--|--|---|---|-----------------------------------|
| | | | | |
| Technical data | Power supply / Motor | 220-230V, 50/60Hz / 24V DC | 220-230V, 50/60Hz / 24V DC | 220-240V, 50/60Hz / 24V DC |
| | Force | 800N / 1000N | 600N / 750N / 1000N | 500N / 600N / 800N / 1100N |
| | Power consumption (power-saving mode) | < 0,5 W | < 0,5 W | < 1 W |
| | Efficiency | 30% | 30% | 40% |
| | Track | single, steel | single, steel | split, steel |
| | Transmission | chain or belt* | chain or belt* | carriage |
| | Speed | max. 14 cm/s | max. 14 cm/s | max.: 18 / 24 / 21 / 18 cm/s |
| | Central control unit | integrated | integrated | integrated |
| | Radio receiver | io-homecontrol; integrated: 868-870 MHz | io-homecontrol; integrated: 868-870 MHz | WIŚNIEWSKI; integrated: 868 MHz |
| | Radio receiver storage: | 30 transmitters | 30 transmitters | 40 transmitters |
| | Two-way radio transmission | yes | yes | yes |
| | Auto selection of operating parameters | yes | yes | yes |
| | Limit switches | encoder + mechanical bumper | encoder + mechanical bumper | encoder + mechanical limit switch |
| | Emergency uncoupling | yes | yes | yes |
| | Application | sectional / up and over | sectional / up and over | sectional / up and over |
| | Operating conditions | -20°C / +60°C ; IP20 | -20°C / +60°C – in a dry room | -25°C / +65°C – in a dry room |
| | Wicket door opening sensor | yes | yes | yes |
| Rotating automatic operating unit head | yes | yes | no | |
| Warranty | 5 years | 5 years | 5 years | |
| Functionality | Obstacle detection | yes | yes | yes |
| | Obstacle detection adjustment | 4 adjustment levels | 4 adjustment levels | 4 adjustment levels |
| | Action following obstacle detection | stop and full opening | stop and full opening | stop and partial opening |
| | Photocells | yes | yes | yes |
| | Automatic closing | 60 sec. / 120 sec. or after photoc. | yes, only with TaHoma Pro | yes / max. 240 sec. |
| | Release in end position | yes | yes | yes |
| | Low energy consumption mode | yes | yes | yes |
| | Independent exterior lighting | yes / 230V, 500 W | no | no |
| | Exterior lighting control | yes | no | no |
| | Auxiliary warning light | yes / 24V, 15 W | yes / 24V, 15W | yes / 24V, 25W |
| | Delayed drive unit light switch off | yes / fixed – 60 s | yes / fixed – 30 s | yes / fixed – 30 s |
| | Independent lighting control in the drive unit | yes | yes | yes |
| | Emergency power supply | yes | yes | yes |
| | Display / LEDs | no / yes | no / yes | no / yes |
| | Partial opening of the door – slightly open | yes | yes | yes |
| | Information about a fault | yes, LEDs | yes, LEDs | yes, LED |
| | Smart home | yes, io-homecontrol technology ⁽¹⁾ | yes, io-homecontrol technology ⁽¹⁾ | yes ⁽²⁾⁽³⁾ |
| Control via the app | TaHoma switch | TaHoma switch | WIŚNIEWSKI Connected | |

⁽¹⁾ – standard, wireless Smart Home, TaHoma switch required; ⁽²⁾ – standard, wireless Smart Home based on Wi-Fi, no additional central control unit required; ⁽³⁾ – option for wired Smart Home systems, CONNEX and OUTPUT boards or RELAY transmitter required for full functionality; ⁽⁴⁾ – RELAY transmitter required

* Extra charge.

io-homecontrol is a modern, safe, and reliable radio technology by Somfy, which lets you control your devices compatible with the smart home concept. Thanks to this technology, the drive unit not only receives commands from the controllers, but it can also send feedback. The io-homecontrol technology makes it possible to connect the METRO Smart io and MOTO io drive units to the TaHoma system to provide additional functions, connecting the garage door with smart devices available at home.

WIŚNIEWSKI 868 MHz is a modern SOMIoq2 two-way radio system for controlling garage doors and entrance gates. Thanks to this technology, the drive unit not only receives commands from the transmitters, but it can also send feedback. The SPARK automatic operating units were also equipped with a wi-fi module, which makes it possible to control the gate from an application installed on a mobile device, giving the drive unit additional functionality.



OPTIONAL ACCESSORIES FOR THE MOTO/METRO AUTOMATIC OPERATING UNITS

WALL-MOUNTED TRANSMITTER



The 3-channel transmitter makes it possible to control drive units and wireless receivers. Examples of use:

- - full opening/closing the door,
- - LED lighting under the tracks, and/or under the track fastener,
- - top panel tilt.

Wireless communication makes it possible to install it in any place and doesn't require any cables.

KEYPAD 2 CODE KEYPAD



The 2-channel code keypad makes it possible to control drive units and wireless receivers.

EXTERNAL RADIO RECEIVER io



Makes it possible to control the drive units of other manufacturers using the Pulsar transmitter. It is a two-channel device which makes it possible to program as many as 32 transmitters.

BACKUP POWER SUPPLY BATTERY



When connected to the METRO Smart io and MOTO io drive, it provides power for several cycles of emergency operation.

MECHANICAL CARRIAGE LOCK



It is an additional safeguard which increases garage door safety when mounted to the carriage.

SIGNAL LIGHT



Supports the METRO Smart io and MOTO io drive units. Warning function. Orange blinking light indicates that the door is operating.

EXTERNAL CODE KEYPAD



The single-channel device can be used to control the garage door with a code. For outdoor installation, requires cabling.

PHOTOCELLS



They prevent uncontrolled door leaf movement when an obstacle is present within the clear passage.



OPTIONAL ACCESSORIES FOR THE SPARK AUTOMATIC OPERATING UNITS

2CH WALL-MOUNTED TRANSMITTER



2-channel device which lets you control both your drive units and radio receivers. Communication between the transmitter and the receiver occurs wirelessly, so the device can be mounted in any place. The wall-mounted transmitter has a feedback function that informs the user about the position of the door using a LED.

WIŚNIEWSKI 868 RADIO RECEIVER



It makes it possible to control other drive units with the DART and DART Vibe transmitters, and the wall-mounted transmitter. The radio receiver is a two-channel device operating at the frequency of 868 MHz, making it possible to program up to 40 transmitters.

DART/ DART VIBE REMOTE CONTROL TRANSMITTER



The transmitter makes it possible to control the operation of several drive units. The DART Vibe transmitter has a feedback function in the form of vibration, which is a confirmation that the signal from the transmitter was received.

ENTRAcode+ CODE KEYPAD



Compatible with the WIŚNIEWSKI 868 MHz radio receiver. Control of up to five devices. Power supply: 4 X AA 1.5[V] batteries. IP 54 protection rating. Up to 30 m range. ENTRAcode+ is a wireless device that does not require any wiring and is designed for surface mounting.

PHOTOCELLS 180



Prevent uncontrolled door leaf movement when an obstacle is present within the clear passage.

SIGNAL LIGHT



Connected to the SPARK drive unit, it has a warning function. Orange blinking light indicates that the door is operating.

CONEX - INPUT BOARD



Additional board with signal, impulse inputs, whose inputs were defined for opening and closing. Compatible with wired Smart Home systems.

OUTPUT - SIGNAL BOARD



Additional board with a signal input. Information about the position of the door: door not open (NO)/door not closed (NC). Compatible with wired Smart Home systems.

LOCK - MOTOR LOCK



A magnetic lock which blocks the drive unit in any position of the door. An additional element able to withstand loads up to 300 kg, increasing door safety.

ACCU - EMERGENCY POWER SUPPLY BATTERY



Connected to the SPARK drive unit, it provides power for several cycles of emergency operation in case of the main power supply outage.

RELAY - ADDITIONAL TRANSMITTER



An additional transmitter with the NO/NC output enabling e.g. switching on lights in the garage and external lights or other electrical devices.



SECTIONAL DOOR



UniPro SNP 2.0 | RAL 7040



UniPro SNP | RAL 9005 | silkline



TECHNICAL DATA

| UniPro SNP 2.0, UniPro SSt 2.0 | |
|--|---|
| Leaf | A panel made of galvanized steel sheet with two-side polyester coating, galvanized and painted on both sides, infilled with high density PU foam $\rho=42 \text{ kg/m}^3$ without HCFC |
| Spring type | UniPro SNP 2.0: extension springs, mounted along the vertical tracks. UniPro SSt 2.0: torsion springs, mounted at the end of the horizontal tracks. |
| Minimum number of cycles | UniPro SNP 2.0: 20 000 UniPro SSt 2.0: 25 000 |
| Thermal transmittance factor U of the panel [W/m ² ·K] | 0.48 |
| Watertightness class | 2 in accordance with PN-EN 13241 section 4.4.2 |
| Wind load resistance class | 3 in accordance with PN-EN 13241 section 4.4.3 |
| Air permeability class | 4 in accordance with PN-EN 13241 section 4.4.6 |
| Sound reduction index Rw [dB] without a wicket door / with a wicket door | 23 in accordance with PN-EN ISO 717-1: 2020 |
| Safety features | Special shape of the panel preventing fingers from getting crushed. Optional accessories: photocells, RC2 anti-burglary kit. |
| Optional accessories | Electric drive, ventilated panel, glazing with an aluminium panel, VISUAL glazing without glazing bars, portholes, glass panes: No-Scratch, GREY, SATIN, SAN R, ventilation grilles, lock, photocells, transmitter. |
| Available panel rib designs | low ribs, high ribs, V ribs, without ribs, caisson ribs |
| Available panel structures | woodgrain, smoothgrain, sandgrain, silkline |
| Available colours: | other RAL, special colours, including wood imitating colours, (film coated panels) |

CONTROL THE GARAGE DOOR WITH YOUR SMARTPHONE!

TaHoma - Your smart home

The io-homecontrol® system with radio transmission makes it possible to wirelessly connect the METRO Smart io and MOTO io drive units to the smart home controlled by Somfy's TaHoma Switch central control unit. Building a comprehensive smart home provides a number of benefits and additional features that enhance your comfort every single day. The app gives you constant access to the most important functions of the elements of your home.



The WIŚNIOWSKI Connected app - new quality as standard

When you choose WIŚNIOWSKI Connected, you don't need a smart home central control unit. WIŚNIOWSKI garage doors with the SPARK drive unit are ready to connect as standard - you can connect them to the smart home without any additional devices or extra charges. WIŚNIOWSKI Connected uses Wi-Fi instead of radio transmission and the app allows you to control the garage door from almost any place in the world.



WIŚNIOWSKI Sp. z o.o. S.K.A.
PL 33-311 Wielogłowy 153
tel. +48 18 44 77 111
www.wisniowski.com

Let us inspire you!
See other solutions from WIŚNIOWSKI!



The products shown in this publication often feature special accessories and do not always correspond to their standard versions • The technical data sheet does not constitute an offer within the meaning of the Polish Civil Code • The manufacturer reserves the right to introduce changes without notice • NOTE: The colours shown in the technical data sheet are for reference only • All rights reserved • Copying and use, in part or in full, is prohibited without the consent of WIŚNIOWSKI Sp. z o.o. S.K.A. • UniPro SNP 2.0, UniPro SSt2.0/02.26/EN